



Litestack Lightweight Chimney Solutions



- Realistic
- Cost effective
- Value adding
- Lightweight
- Quick and easy to install
- Strong and weatherproof
- Limitless variations

Chimneys have always been a strong feature of traditional structures and have added greatly to the aesthetic appeal of the built environment. Whilst chimneys used to be highly functional, today they are viewed as heavy and complex elements that add significantly to the cost of the build.

Despite the fact that modern heating systems and building techniques can make traditional chimneys unnecessary they are still in demand – not only due to stringent planning and conservation restrictions, but also to satisfy customer tastes. Litestack offers a cost effective solution that is quick and easy to install and retains all the aesthetic appeal of a traditional chimney.

Litestack provides a range of complete chimney solutions based on a ready to install, one-piece chimney stack.

Lightweight and very easy to use – the chimney is simply lifted into position, bolted onto the roof trusses



and leaved in the normal way. These chimneys can be positioned on the gable end, along the ridge or mono pitched.

Advanced techniques yield a product of exceptional quality. Based in the UK, attention to detail is our hallmark. Bespoke and personalised products are a pleasure.

chimney specifications

Each chimney can be tailored as much or as little as required to meet your needs – we can match the pitch, the texture, the colour, the pots and the capping to suit your build.

The most popular Litestack chimneys are those based on our four stock designs – the Kent, Norfolk, Warwick and Staffordshire. For each of those you can specify the brick, pot and capping details to match your development.

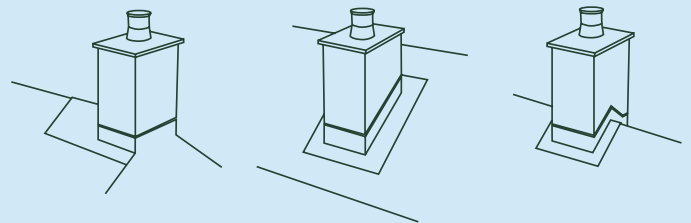

End Ridge

Mono Pitch

Mid Ridge

Each chimney is available in an end ridge, mono pitch or mid ridge format. We now have the facility to pre-lead your chimney to enable even more rapid installation.



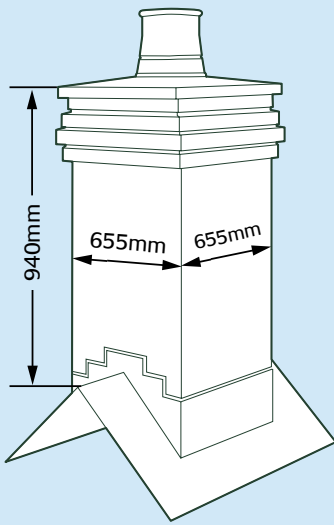

KENT

This is a single pot chimney with a flat capping and three band corbelling. The smooth lines of this compact chimney ensure that it is flexible and sits well with many contemporary housing designs. The example above shows the Kent chimney finished in a red stock brick with Portland stone capping.

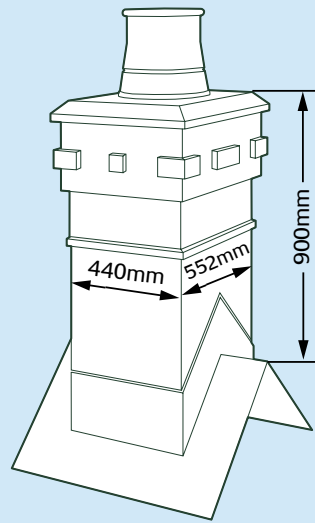

Norfolk

This single pot chimney incorporates many traditional building features including a collar of corbelled bricks above a 30mm band. The plinth capping has clean angled lines. The example above shows the effect of using contrasting brick colours in the corbelling.



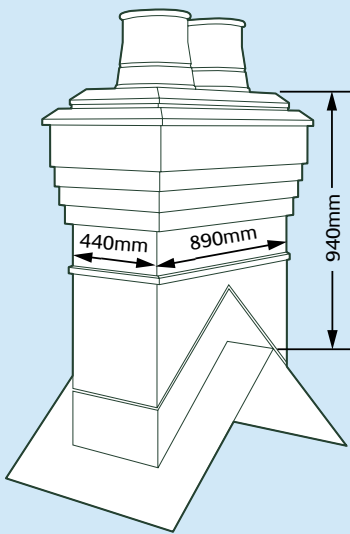

Warwick

The twin pot Warwick is a large handsome chimney. Its bulk is emphasised with seven stepped corbelling and two course brick capping. The example above shows the broad side of the chimney perpendicular to the ridge.

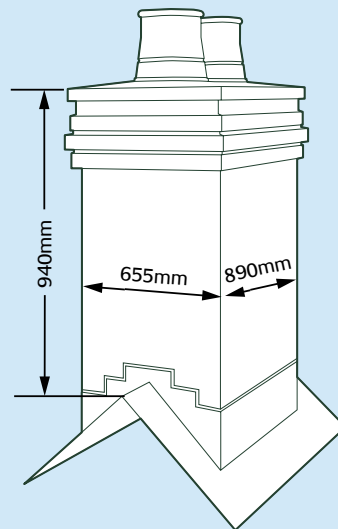

Staffordshire

The Staffordshire is the 'big brother' of the Kent, with the same flat capping and three band corbelling. These two pot chimneys work well both in combination with the Kent and alone. The example above shows the Staffordshire chimney finished with a red handmade brick with Portland stone capping.

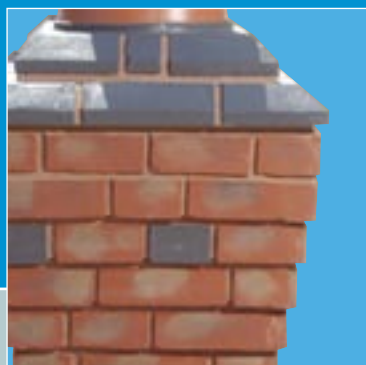



“The stone and render chimneys are remarkable; a perfect match was achieved on our Cotswold stone site in Gloucestershire. We are keen to make use of these chimneys wherever possible.”

Steve Walters – Charles Church (Western) Ltd.

Finishes

The Litestack Chimney range has now been extended to include both stone and render finishes in addition to our familiar brick chimneys. As with our brick finishes, each chimney can be carefully matched to the materials to be used on your particular project.

1. Natural Stone,
2. Smooth Render,
3. Reconstituted Stone,
4. Roughcast Render.



“We use Litestack chimneys because they are indistinguishable from the real thing, the whole system is so quick and easy.”

Gary Nicholas – Quietwater Properties Ltd.

“We chose the Litestack chimney as they look extremely realistic. There are so many physical and financial advantages compared to a brick chimney, it is definitely the way forward.”

Jason Mann – Site Manager Westleigh Development.



Pot Options

Chimney pots can be mixed and matched to suit the style and size of chimney. Pots are available in a Terracotta, Black or Buff finish.

Venting

All chimneys can be supplied with an approved gas terminal and suitable flue pipes.

Installation

Each litestack chimney is supplied with a complete fixing kit and detailed fixing instructions.

The chimneys can be installed immediately after the rafters are in place using telescopic fork lift or light crane.

Packaging

Each unit is palletised and packed with cardboard for protection during transport and storage, ensuring that Litestack chimneys are delivered in perfect condition.

Orders of five chimneys or more will be supplied with a free lifting strap.

Accreditation

RAPRA Tested for long term UV/Weather conditions.
BRE wind tunnel tested.

A project supported by the
Manufacturing Advisory Service
– West Midlands

Tested and validated by
RAPRA?Technology

Litestack is developed in co-
operation with Polymer Cluster



Approved Distributor

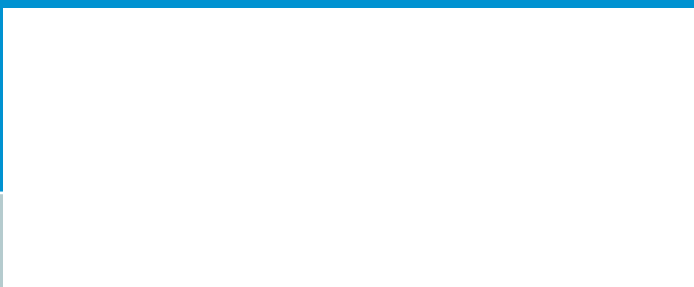

Banbury Innovations Ltd.

2 Sands Lane
Bratton Westbury
Wiltshire BA13 4TL

T: 0845 688 8835
F: 0845 688 8845

E: sales@banburyinnovations.co.uk
W: www.banbury-grp.co.uk